

Profiled Handle (PP) or (PPC)



WARNING !

Closing system only available with ALUCOFFRE !

The roll-up door can be closed with a profiled handle without key (PP) or with key (PPC). The second profile is equipped with an extending part which makes it possible to grip the door and manipulate it as well as stopping it in the up position. When it's a simple handle with key, the roll-up door is locked in the lower position with a rod lock system in each track.

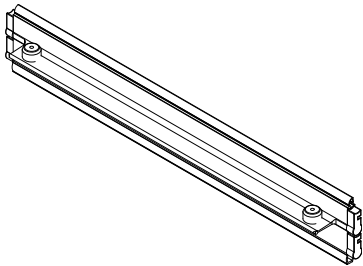

PP external view

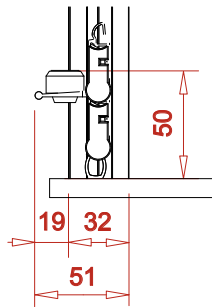

PP side view

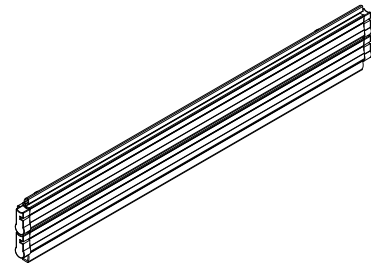

PP internal view

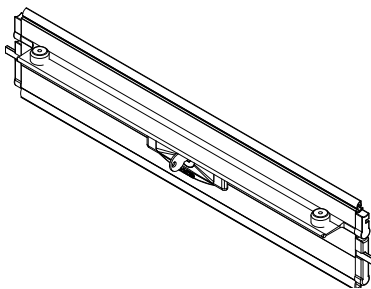

PPC external view

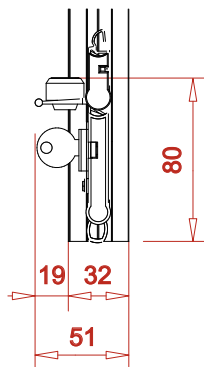

PPC side view

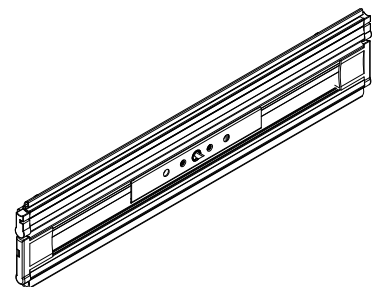

PPC internal view

EXPLODED VIEW PROFILED HANDLE SYSTEM CLOSING

Compatible options with SIMPLE HANDLE CLOSING SYSTEM

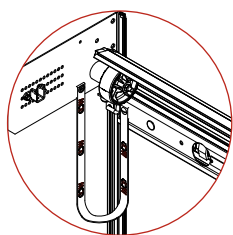

Pull strap
See Page 4.3.1



Interior unlocking
See Page 4.4.1

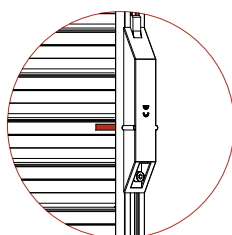

Sensor
See Page 4.5.1

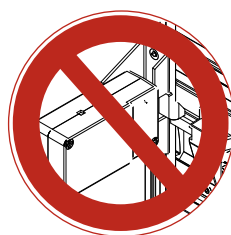

Electric locker
See Page 4.6.1

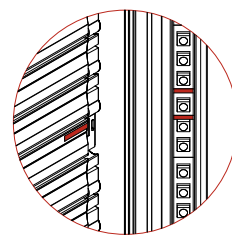

LED light
See Page 4.7.1

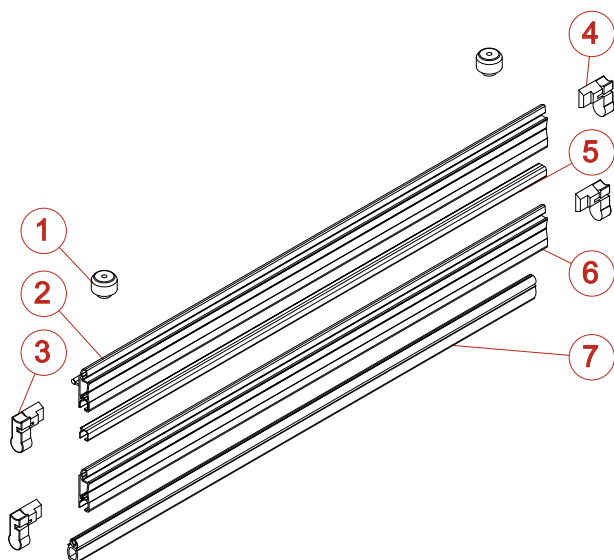

REP	CODE	DESCRIPTION
1	4219	RUBBER END STOP
2	1003	REINFORCED SLAT (M)
3	4007	LEFT REINFORCED SLAT CAP
4	4008	RIGHT REINFORCED SLAT CAP
5	2004	INNER SLAT SEAL (M)
6	1001	ABE SLAT 30 (M)
7	2010	BOTTOM SEAL (M)

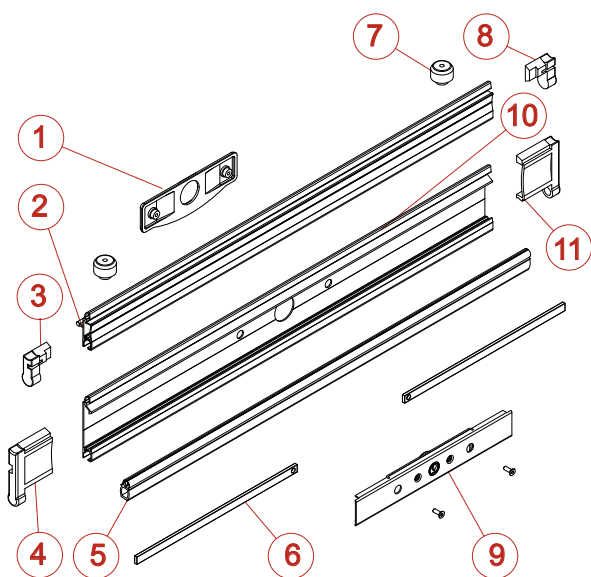

REP	CODE	DESCRIPTION
1	3233	KEY LOCK HOLDER
2	1003	REINFORCED SLAT (M)
3	4007	LEFT REINFORCED SLAT CAP
4	4005	LEFT ALU60 SLAT CAP
5	2010	BOTTOM SEAL (M)
6	3220	STAINLESS ROD
7	4219	RUBBER END STOP
8	4008	RIGHT REINFORCED SLAT CAP
9	3960 à 3963	ROUND CYLINDER LOCK
10	1002	ALU60 SLAT (M)
11	4006	RIGHT ALU60 SLAT CAP